

# Stock program

Insert-Line

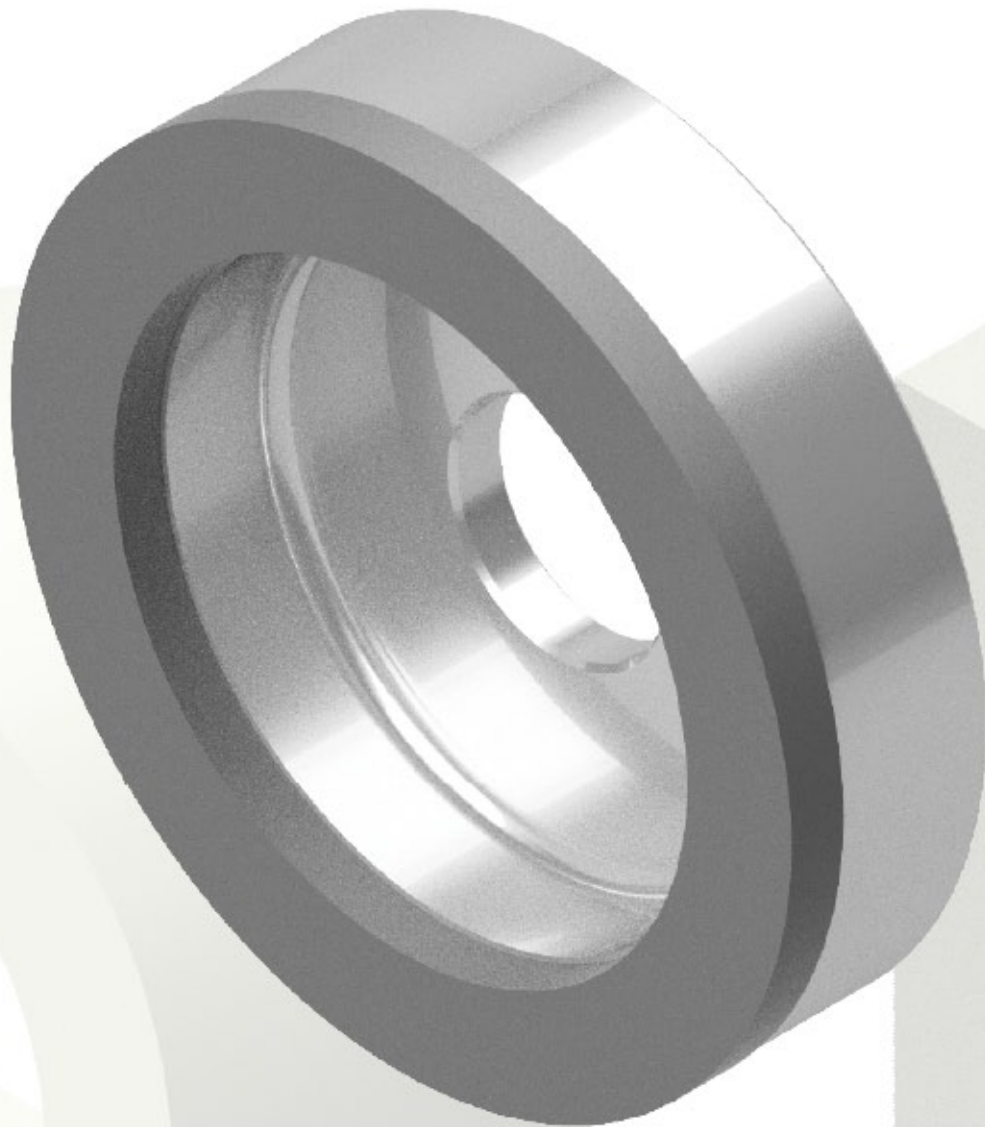

for machining  
PCD and PCBN inserts

## Stock program Insert-Line for machining PCD and PCBN inserts

- high removal rate/ short grinding time
- high cutting edge quality
- longer wheel life
- economic price



**Diamond Cupwheel**  
6A2-150-20-10-EPx-D10-TB  
Bore: 40H7  
ID 214761



**Sharpening Stone**  
FORM 9010 25x13x100  
EKW 500/5 I 7/8 V5901Z  
ID 210387



**Diamond Cupwheel**  
6A2-350-15-7-EPx-D12-TS  
Bore: 310H6  
ID 215951 (NA) und 206328 (WB)



**Sharpening Cup**  
FORM 6 120x95x60,33 - W15xE10  
SCG 220/4 M 7/8 V7500Z  
ID 203044

### Practical example

Cycle time reduction 15 %

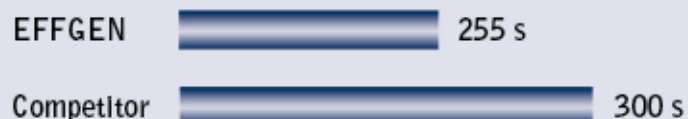

Insert VCGT 160409 PKD  
Grinding wheel 2A2T-250-12-5-EPx-D15-TA

*available from stock, subject to prior sale, prices on request*