

FlexFile



Use

- Blending and removal of superficial defects
- Burrs
- Post processing of tools of all kinds

Advantages

- Fracture resistant
- No scratching, especially on edges and radius areas
- Slightly flexible, adapts to contours

Application

- In all industrial sectors including, Aerospace, Mould and Tool, Turbines and Pumps and Medical
- Handcraft and DIY

Available Flex File Variants

Types of Grain:	Silicon carbide (SCG) Aluminum oxide (EKW)
Grain size:	F 60, F 120, F 220
Bond type:	Standard BGF730 Extra flexible BGF460

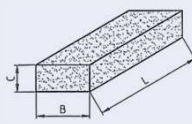
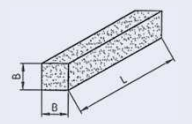
FORM 9010	FORM 9011
	
Dimensions B x C x L	Dimensions B x B x L
25x13x100 mm	10x10x100 mm
25x13x150 mm	15x15x150 mm
25x13x200 mm	20x20x200 mm

Other dimensions available on request!

Lapport Schleiftechnik GmbH Phone: +49 (0) 63 03 – 92 11 – 0 E-Mail: vertrieb@lapport.de www.lapport.com

